

# HAND PALLET TRUCK



Vol. 5



**AAK** Handling Equipments Pvt. Ltd.

Plot No. 174, Sybly Industrial Area Abupur, NH-58, Muradnagar, Ghaziabad-201206,  
Uttar Pradesh, India Ph.: +9101232-262931 E-mail : sales@aakhandling.com, www.aakhandling.com

# AAK HANDLING EQUIPMENT'S

## Hand Pallet Truck-2.5 Ton

**A**ak has designed the APT 2.5T to be as maintenance free as possible. Features such as a strong, robust frame and linkage together with high quality forgings and welds ensure better longevity. The APT 2.5T features the extensive use of "sealed and lubricated for life" bushings and bearings where others feature grease fittings. The APT 2.5 hydraulic pump is fully serviceable and repairable. Each part is economical to replace and readily available. Crown engineered options include handbrake, galvanisation wet application treatment and a choice of wheel compounds. The APT family also includes models with weighing scale and high-lift forks.

### Feature:

- Easy 3 position control handle-- Raise, Lower, Neutral.
- Ergonomic power coated handle, which is comfortable and convenient to operate.
- Fork lowering speed is controllable, operated by hand control as well as foot pedal.
- Integrated casting pump & welded pump.
- Extra reinforced on fork frame.
- Solid steel lifting rods for extra strength.

**Wheels:** Nylon wheel, Polyurethane wheel.



### Full-function control handle with neutral



A few strokes of the large steering handle provides a full 110 mm of lift. A convenient control lever has three positions: Raise, Neutral and Lower.

The neutral position eliminates backpressure from the pump, allowing the handle to move freely. Lowering speed is controlled at all load capacities. The handle is spring loaded and returns to a vertical position when released. The handle thickness and angled shape is designed for the most fatigue free operating position.

### Hydraulic unit proven reliability

One of the most critical parts of a hand pallet truck is the hydraulic pump. It must withstand thousands of lift/lower cycles, and yet be easy and inexpensive to repair. The Aak APT 2.5 is life tested to a minimum of 1,00,000 pump cycles. The enclosed lift pump means that there are no exposed parts such as valves or levers, which can be broken or damaged.



### Strong fork design

The C-channel fork design uses formed steel members with steel reinforcing at key stress areas. Evidence of Aak's emphasis on reliability is apparent with the choice of boxsection pushrods which are stronger and more durable than other pushrod designs. The proof is the full load capacity of 2300 kg with all fork lengths up to 2 m.



# AAK HANDLING EQUIPMENT'S

## Durable frame and high quality wheels

A robust, cross-braced frame provides unrivalled strength and durability. Steel forgings are used on the lift linkage. For easier handling and control, the APT has large 180 mm steer wheels. Steer and load wheels use high quality compounds that lower rolling resistance, provide long life, and are smooth and quiet in operation.

To ensure continuous contact with the floor, the wheels articulate to ensure you never have the weight of the load on just one wheel. Hubcaps protect the bearing and steer axle from side impact damage and contamination.



## Long-term value

Aak utilizes high-grade steel combined with extra weld length and additional stiffening where necessary, especially in the area of apron pivot bosses. Thorough preparation of the assemblies before receiving a powder paint process ensures the highest levels of paint adhesion and long term protection.



## Easy pallet entry and exit

Easy pallet entry and exit The fork tip and tapered mounting bracket design for the APT entry roller affords protection for the roller itself and the load wheels. The exit ramp, riser and the exit roller are engineered for long life and impact resistance. The combined effect for the operator is excellent entry and exit from pallets, even when the pallet is empty. A low 85 mm lowered fork height allows easy access to difficult or damaged pallets.



| DESCRIPTION              | UNIT    | APT 2.5T - 550N/P | APT 2.5T - 685N/P    |
|--------------------------|---------|-------------------|----------------------|
| Capacity                 | Kg      |                   | Up to 2500           |
| Overall dimensions       | mm      | 1550 X 550 X 1180 | 1620 X 685 X 1180    |
| Min. Fork Height         | mm      |                   | 85                   |
| Max. Fork Height         | mm      |                   | 190 - 200            |
| Max. Lifting Height      | mm      |                   | ≥110                 |
| Fork Outside Distance    | mm      | 550               | 685                  |
| Fork Length              | mm      | 1150              | 1220                 |
| Fork Width               | mm      |                   | 150                  |
| Load Roller Double Wheel | mm      |                   | ø80 x 70             |
| Steering Wheel           | mm      |                   | ø180 x 50            |
| Fork Thickness           | mm      |                   | 3.2                  |
| Pump                     | Std     |                   | Standard Machined    |
| Handle                   | Std     |                   | Mild Steel           |
| Structure                | Ms Fab. |                   | Mild Steel           |
| Net Weight               | Kg      | 68/72             | 70/74                |
| Material of Wheel        | Std     |                   | Nylon / Polyurethane |

# AAK HANDLING EQUIPMENT'S

APT 2.5T - 550N/P

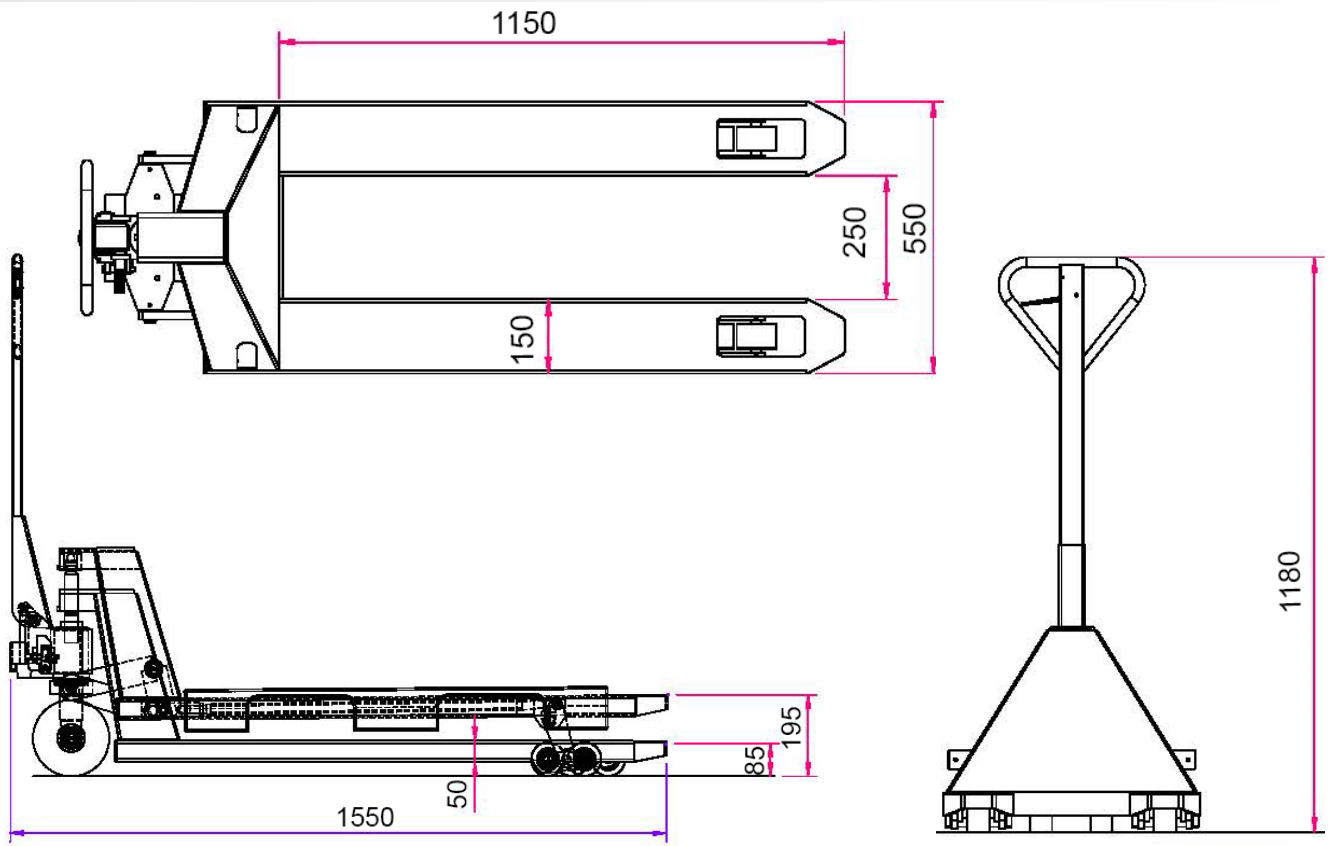

APT 2.5T - 685N/P

